

DİKİLİ TİP YAN KAPAK MONTAJ  
WALL MOUNT DOOR TYPE

DİJİTAL Termostat KONTROLÜ  
DIGITAL DISPLAY CONTROLLER

PASLANMAZ ÇELİK  
STAINLESS STEEL

KOLAY BAKIM - AÇILABİLİR KAPAKLI  
EASY MAINTENANCE - OPENABLE FRONT DOOR

A SINIFI EKİPMAN  
A CLASS EQUIPMENT

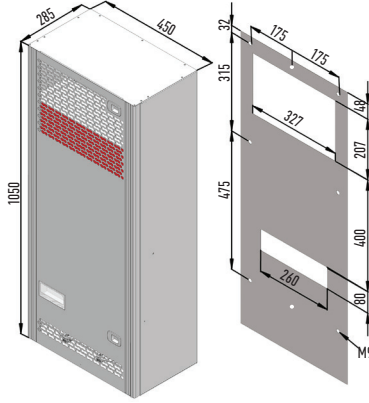
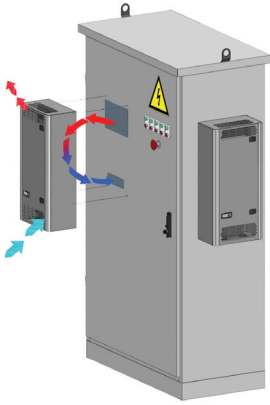

## TEKNİK BİLGİLER

## TECHNICAL DETAILS

## SVK-4000

Soğutma Kapasitesi (L35 / L35)	Cooling Capacity (L35 / L35)	3700 W
Soğutucu Gaz Tipi	Type Of Refrigerant	R 134a
Soğutucu Gaz Miktarı	Amount Of Refrigerant	1050 gr
Fabrika Termostat Ayar Değeri	Default Thermostat Setting	34 °C
Difransiyel	Hysteresis	4 °C
Dış Ünite Fan Debisi	External Circuit	1425 m <sup>3</sup> /h
İç Ünite Fan Debisi	Internal Circuit	1175 m <sup>3</sup> /h
Enerji Frekansı	Rated Frequency	50/60 Hz
Enerji Voltajı	Input Voltage	380 V. - 415 V.
Çekilen Güç	Power Absorbed L35 L35	..... W
Çalışma Akımı	Running Current	2.2 A
Başlangıç Akımı	Starting Current	3.6 A
Ağırlık	Weight	57 kg
Yükseklik x Genişlik x Derinlik	Height x Width x Depth mm	1050 X 450 X 285
Metal Aksam Cinsi	Corrosion Protection (cover)	Stainless
Montaj Şekli	Orientation	Wall Mount
Koruma Sınıfı	System of Protection	IP 54
Çalışma Aralığı	Ambient Air Temperature	0 °C ... +55 °C
Kompresör	Compressor	Embraco
Fanlar	Fans	EbmPapst

